



AL Harb Medical Supplies is a unique Company, designs, install and markets a broad range of products for virtually every department in the health care facility. Our mission is to provide state-of-the-art products that facilitate the caregivers role in providing the best outcomes for patients providing a complete cycle of : Designing , supplying , installation & After sales service with the assistance of our professional certified staff

As we are the Agent of the most unique Brands in the Medical field

Our broad range of products including

Headwalls and Casework

ICU ,OR Booms/Pendant Systems

Beds

Furniture

Lights

Diagnostic Equipment

Suction & Oxygen Therapy Equipment

Air & Vacuum Systems

Pipeline Equipment

Equipment Mounting Solutions

Safe Patient Handling Solutions

Nurse call System

Medical display systems

Mammography displays

Diagnostic displays

Clinical displays

Surgical displays

Dentistry displays

Medical Keyboards & Mouse

Radioprotection

Nuclear Medicine

Stainless steel Furniture



Samer A.harb
Chief Executive Officer

Amico

Architectural Headwalls
Interiors/Medical Grade Casework
Suction & Oxygen Therapy Equipment
Safe Patient Handling Solutions
OR Booms/Pendants
Surgical Lights
Equipment Mounting Solutions Medical
Gas Pipeline
Patient Room Furniture

GETT[®]

glass surface keyboard & Mouse for medical and dental applications

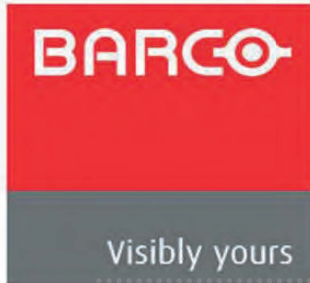

Clinical displays
Diagnostic displays
Mammography displays
Surgical displays

GRUNDIG

speech recognition Micriphone with medical vocabulary



TR EQUIPMENT

AMETEK[®]

Nurse Call System
Solutions For Nursing Facilities

Shower
Baths
Mobile Bath Lifts
Rehab

Pland

Strength in stainless steel

stainless steel medical furniture
Scrub Sinks
Slop Hopper
Plaster Sinks

**RADIOPRO
TECH**
Radioprotection & Nuclear Medicine

Radio protection
Nuclear Medicine



Whitehall Manufacturing
Manufacturer of Healthcare and Rehabilitation Products since 1946

Patient Care Units
Stainless steel Medical furniture

PROJECT APPROACH

Plan-Spec

With decades of experience in construction projects, we will review plans and specifications to determine the lowest possible cost and build per design.

Design-Assist

We work closely with the design and construction team to clarify the operational benefits and review alternate options based on price and performance.

Design-Build

These projects bring together the owner, architects, general contractors, engineers, and other trades to meet the owner's requirements for the process.



Queen Alia Military hospital- JRMS

Integrated Project Delivery

Being able to integrate all the resources for one company is a task, and we regularly participate in collaborative design and planning processes to accommodate the unique needs of each project.



PROJECT EXECUTION



Prince Talal Military Hospital- JRMS

Acquisition

- » Qualify - Go/No Go
- » Estimate the Project
- » Value Engineering
- » Price the Project

Planning

- Contract / Scope Negotiation
- Turnover Meetings
- Labor Validation
- Purchasing, Material & Site Plan
- Manpower / Productivity Plan

Execution

- » Prefabrication
- » QA/QC Plan
- » Project Billings
- » Productivity Management
- » Material Management
- » Manage Subs & Vendors
- » Cost to Complete Forecasts
- » Change Order Management

Closure

- » Start-Up
- » Commissioning
- » Closeout Meeting
- » Turnover to Service
- » Lessons Learned



Queen Alia for Heart Institute

QA / QC

Having successfully completed many projects in hyper quality controlled environments such as the pharmaceutical and Hospital critical industries



Amico
GROUP OF COMPANIES

Serenity Panel Walls

Amico's Serenity Panel Walls offer you limitless design and adaptability for future modifications. The streamlined installation of our panel wall seamlessly integrates all of your services and equipment

Fully modular and reconfigurable

Custom built

Integrated rails

Infection control/ease of cleaning





Amico Interiors Corp



Before

Amico Interiors Corp

Overbed Tables & Casegoods

Amico Patient care works with you, customizing all of your furniture needs to match your room decor. Choose from our wide variety of finishes complete your rooms.

Our overbed tables are available with different surface styles and options to accommodate various department needs throughout your facility.

Our bedside cabinets, carts and wardrobes offer attractive storage options for the comfort of your patients and keep things organized for clinical staff.



Overbed Tables



Single or Dual Table Top

Whiteboard

Jellybean

Bedside Cabinets

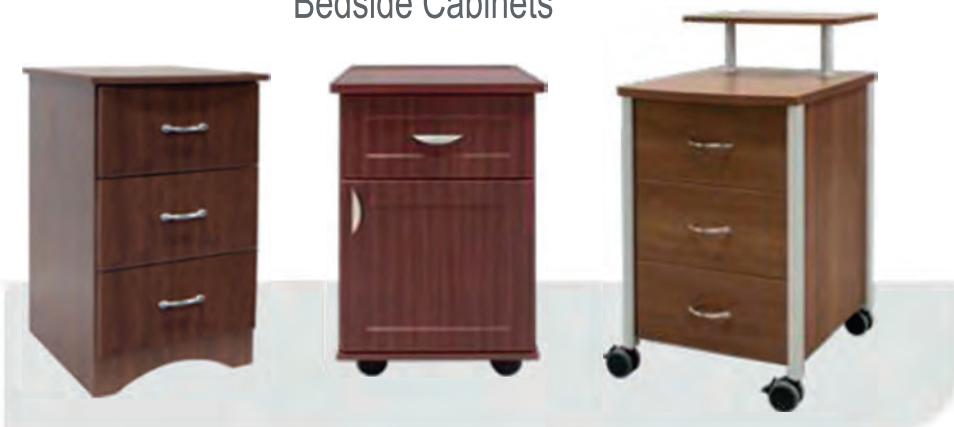

Equipment Mounting Solutions & IT Carts

Amico has become known as an Innovator In the medical Industry, creating a line of Healthcare IT Mounting Solutions that suit the needs of healthcare providers.

We strive to provide caregivers with reliable and attractive work-flow solutions. Our products are compatible with every major manufacturer so they work the way you expect them to with no headaches.

Amico's General Room Accessories offer unique benefits to healthcare providers Including flexibility, adaptability, productivity, aesthetics and ergonomics.

IT Mounting Solutions



Condor

Falcon



Monitor Arms



AHM

SSM

General Room Accessories



Instrument Mounts

Baskets

Roll Stands



Diagnostic Equipment

The Amico Diagnostic Station with Smart Bulb System protects and extends the life of the bulbs while lowering energy consumption. Anti-theft Instrument heads can be locked securely in place, reducing the cost of lost equipment



Amico's Blood Pressure Cuffs and Components are made with care and quality to ensure they exceed the industry standard. Our cuffs are available in all sizes and are color coded for quick and easy identification.



Patient Room, Procedure & Exam and Architectural Lighting Solutions

Solar Series Eclipse LED Light



Up to Three Functions per Fixture

Solar Series Multifunction LED Light



Up to Five Functions per Fixture

Skyline Overbed LED Light



Up to Four Functions per Fixture

Solar Series Duo Med LED Light



Up to Three Functions per Fixture

LightMaster Multifunctional Switch



Control Up to Five Lights In a Single Keypad

Lunar Series Night Light

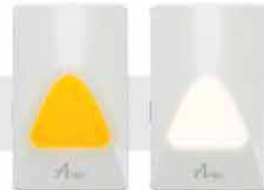

Available with Photocell Technology

Mira Series LED Light



Available In Mira 50, 65 and 90 LED Lights

Gamma Series LED Light



Ideal for General Examinations

Clarity Series LED Light



Ideal for Task and Reading Purposes



Operating Room Lights

Our eco-friendly and long lasting iCE LED Surgical Lights last a minimum of 50,000 hours, translating into decades of energy cost savings. The ultra-efficient technology leaves a Green Footprint wherever it is installed



Amico iCE LED Surgical Lights have superior shadow reduction and deep cavity illumination. This is created with multiple overlapping beams and are adjustable by turning a centrally mounted handle to create a long homogeneous column of light. This allows surgeons to effortlessly direct a precise light pattern into the surgical field while providing the ideal balance of shadow reduction and deep cavity illumination



Patient Lift

The Amico Golift is an ideal ceiling lift/hoist system designed to safely lift, transfer and reposition a patient with as little effort as possible for the caregiver.

The Golift can be integrated into our Amico headwalls, pendants as well as our traditional ceiling track systems, making it an ideal and complete solution for both your ICU and OR. Golift is the world's smallest 700 lb patient lift that weighs less than 10 lbs!



Booms/Pendants

Complete your ICU or OR with our movable pendant systems equipped with state-of-the-art electric brakes that provide a user-friendly experience for your caregivers.



Integrated equipment such as Amico's Golift ceiling 11ft and equipment transport systems provide a safe and effective way to transport patients and IV pumps from the ICU to the OR.



Beds & Stretchers

Amico Beds and Stretchers incorporate distinctive features to assist caregivers by providing a more meaningful level of care and comfort for patients. A full line of thick, durable, flame resistant support

surfaces and stretcher pads are also available



MedSurg Beds
(available with or without
scale)



Fifth Wheel



Stretchers
(standard and
bariatric)

Suction & Oxygen Therapy Equipment

Vacuum Regulators

NEW!
The Sentinel
Vacuum Regulator

THE ONLY REGULATOR
THAT DETECTS
CONTAMINATION!



Surgical/OR (0 - 750 mmHg) Pediatric (0 - 160 mmHg) Neonatal (0 - 100 mmHg) Adult Intermittent (0 - 300 mmHg)
Optional Color Coding by Model Type



Upgrade to a Digital Gauge



Clear Back Plate
Identify Contamination
Instantly

Flowmeters



Thorpe Style

Dual/Y-Block Flowmeter Assembly

Dial Style

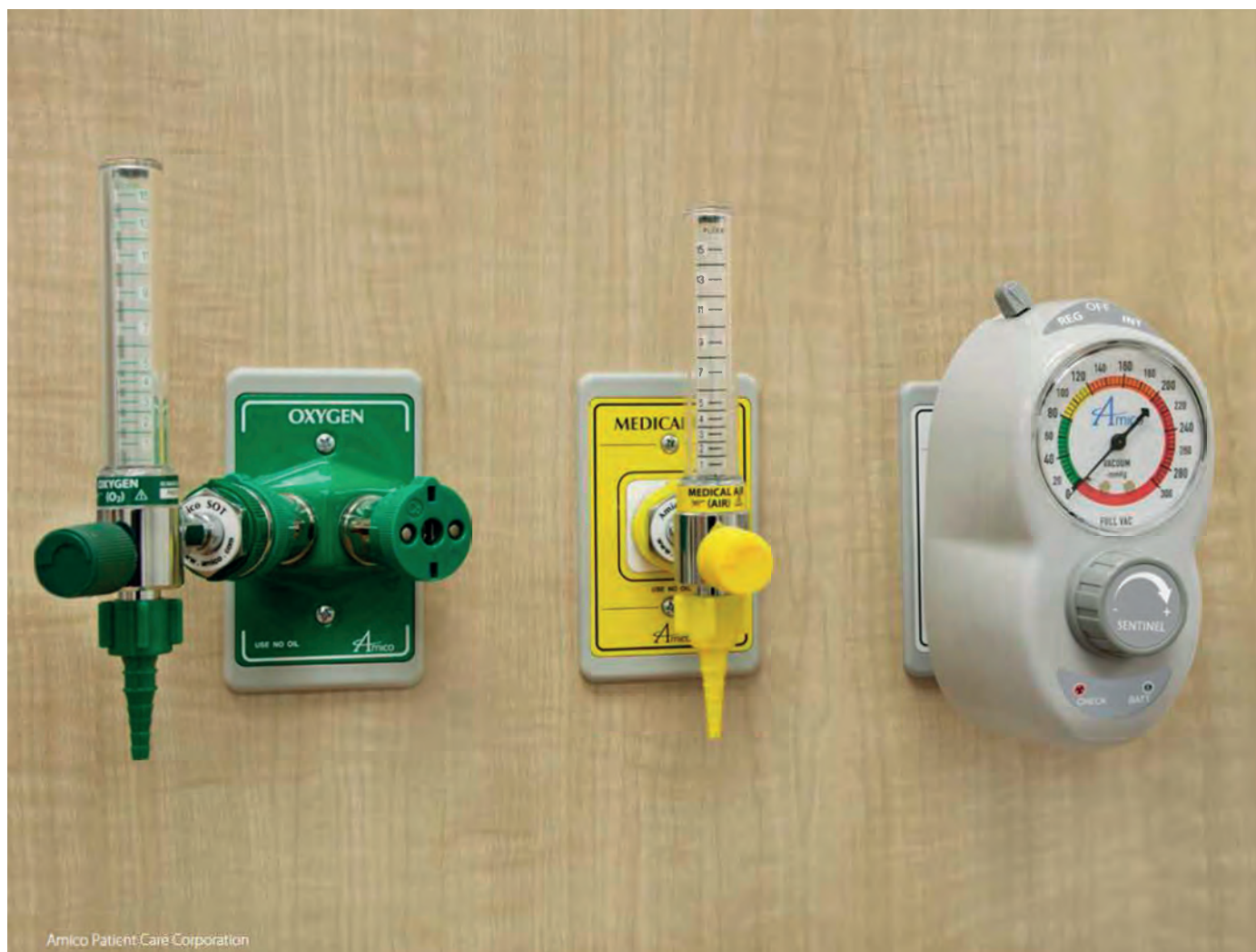

Medical Gas Pipeline Equipment



Alarm Valve Combo



Economy Manifold



Digital Manifold



Ethernet Master Alarm



Gas Control Panel



Dual Outlet





Solutions for “Best in Class”
Acute Care

5000

Responder[®]

5000



A solution that is simple to install and easy to use to modernize the quality of care across departments for a more consistent, high-quality patient experience with:

- Standardized corridor light colors, flash rates and ring tones
- Accurate patient information for enhanced privacy and error reduction
- Proven best practices for quality of care
- Simple, smart phone interface
- Consistent station labels and colors provide ease-of-use for staff
- Data-driven reports to improve standardization

Responder Solutions are proven around the world.

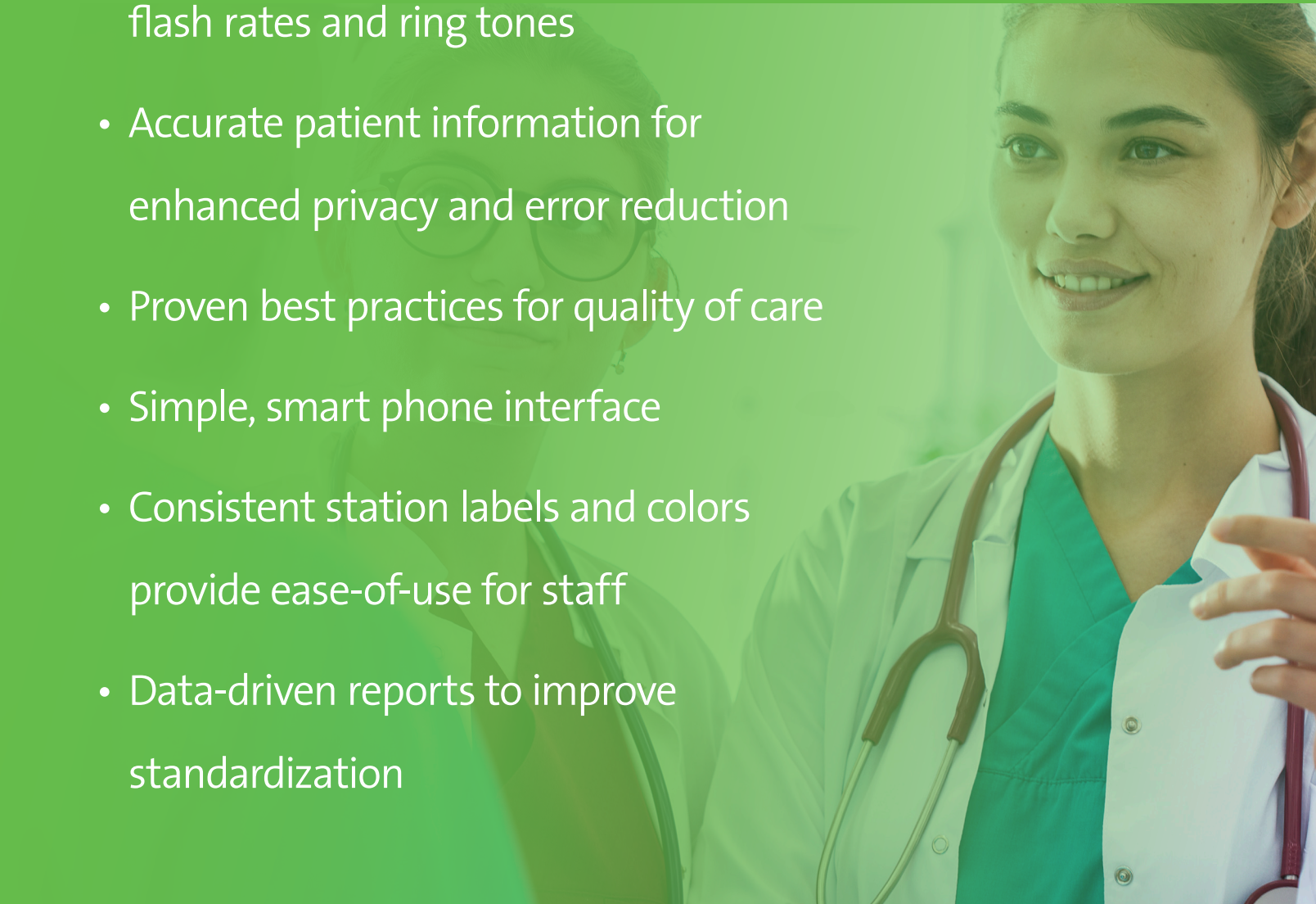

Welcome to a higher level of quality care



Patients have a choice when it comes to their healthcare providers. Responder 5000 can take your facility to the next level to make it a top destination for those that want the most modern, high-quality care.

The Rauland Responder[®] 5000 Nurse Call Communication System is an easy-to-use, efficient communication solution that will standardize the patient experience across departments and facilities for a more consistent, high-quality experience. Responder 5000 system's comprehensive and automated processes and reporting functions raise staff proficiency.

Rauland

Responder 5000



RESPONDER 5000 SOFTWARE IS THE KEY TO DRIVING AN ENVIRONMENT OF CARE THAT MEETS THE TOUGHEST ACCREDITATION STANDARDS INCLUDING SERVICE, MAINTENANCE, RELIABILITY AND CLEANING. FOUR MODULES PROVIDE ACTIONABLE, REAL-TIME INFORMATION:

ACTIVITY BOARD is the centerpiece of Responder 5000, offering a customizable visual overview of all staff activity and patient status on a single display. In real time, staff members can view 11 different data elements including location, and patient and physician information, in one or multiple units in the facility.

PATIENT DETAILS displays a compact view of all patients within a facility to ensure an educated and professional approach in all patient interactions. Staff always have accurate information for a more consistent, high-quality patient experience. Using approved member access, staff can add or edit patients' personal and location information anytime as needed; information is updated to Activity Boards and Reports.

ADMINISTRATION enables total control, customization and maintenance of the system. This module allows system administrators to manage staff members' information and authentication credentials, access to the system, patient detail information and Activity Boards from different units of the facility.

REPORTS measures productivity and call volumes and provides clear, customizable and precise formats to help drive decision making and manage workloads. Use information to identify areas of improvement where better standardization could be used. Data can be summarized to specific units or aggregated for the entire hospital. Reports can be configured to be shared with any staff and automatically emailed so results can be reviewed at any time.

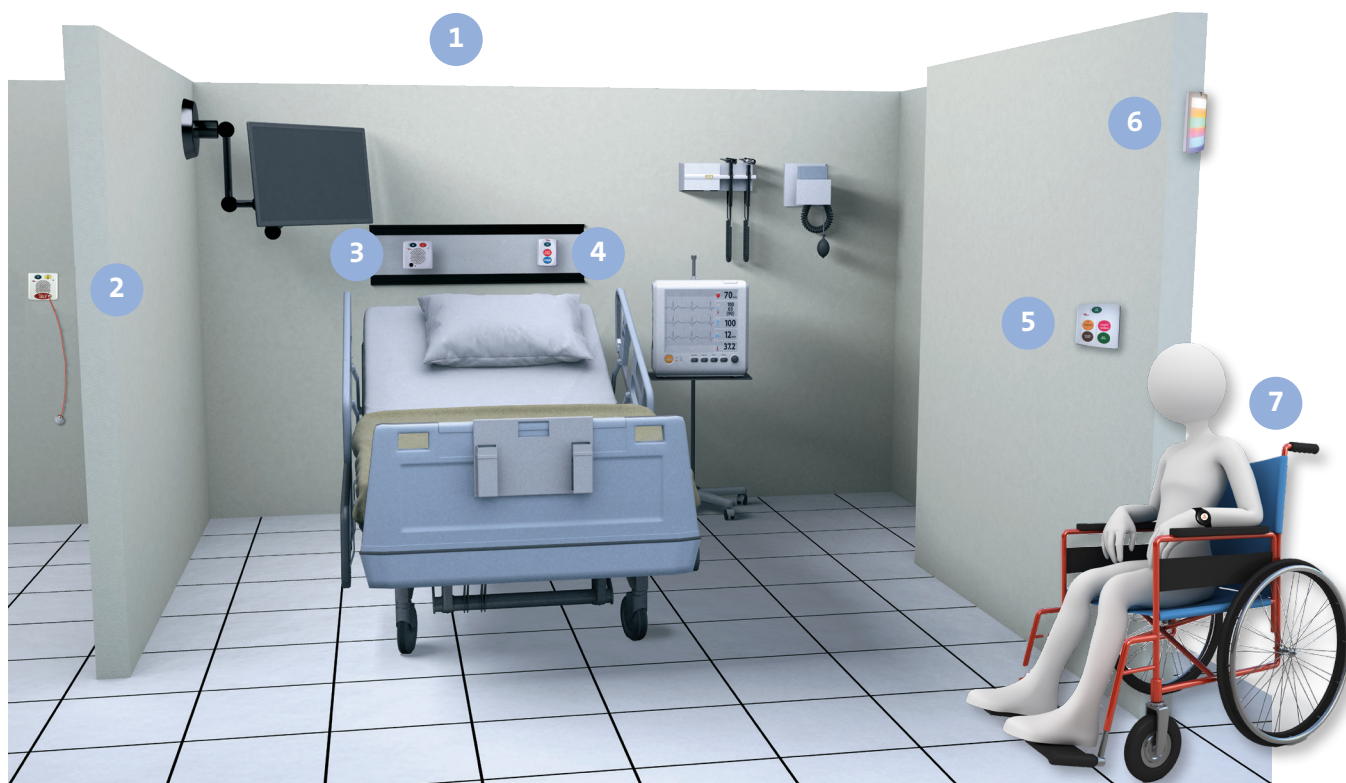

- **Enhance facility appearance:** Standardized corridor colors, flash rates and ring tones at the nurse console demonstrate an organized, professional and modern approach to patients.
- **Improve clinical consistency:** Consistent station labels and colors provide consistency and ease-of-use for staff. With Responder 5000, staff will always have accurate patient information available – ensuring patient privacy and reducing the chance of medical error.
- **Facilitate first-rate care:** Effective, timely care for patients helps eliminate clinical delays and ensures their dynamic needs are met.
- **Take advantage of low cost of entry:** Add value and help increase revenue without expensive servers, licenses or infrastructure.

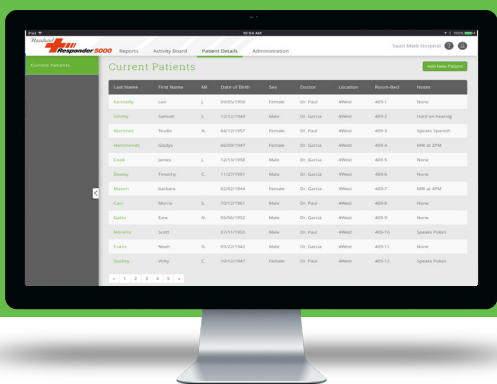

- **Identify areas of improvement:** Reporting software provides management with the ability to identify areas where additional improvement or standardization is needed, and pinpoint useful data that can be used in staff training

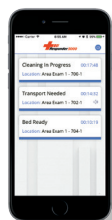

- 1 Smart Phone App**
App is designed for either visual/tone or full voice communication. Smartphones on any SIP-capable device provide instant communication and group notification without middleware. Integrates fire and security alarms into the nurse call system, for instant visibility.



- 2 Bathroom Station**
Audio pullcord in patient's bathroom allows patient to communicate routine requests or distress verbally, directly to caregiver, as well as helping to avoid falls.



- 3 Room Station**
Communicate directly with patients to hear their needs, eliminate unnecessary trips to their room and optimize available time.



- 4 Emergency Station**
Define unique call-in priorities for pushbuttons, which are customizable to the needs of your unit.



- 5 Workflow Station**
Initiate up to four new workflows with the push of a button for more efficient management of your patient's needs and clinical tasks.



- 6 Corridor Light**
Programmable colors and flash rates provide a wide range of indications for alarms, staff registrations and room status.



- 7 Rauland EveryWear™**
Real-time wearable location system allows patients to request help and monitors staff location and equipment to improve care and productivity.



Efficiency, simplicity— worldwide reliability



Responder 5000 delivers the capability to provide a communication environment that fosters staff efficiency while enhancing staff and patient satisfaction throughout your facility. Today, tomorrow and from now on.

To schedule a personal demonstration or learn more, visit www.rauland.com.



Barco Healthcare

Medical solutions portfolio



About Barco

Focused on transforming the delivery of care, Barco connects healthcare professionals at every patient touch point, from the imaging room, to radiology, through specialist consultations and in the surgical suite. We offer a network of medical imaging solutions that deliver the complete picture to support more informed decisions, when and where it matters most.

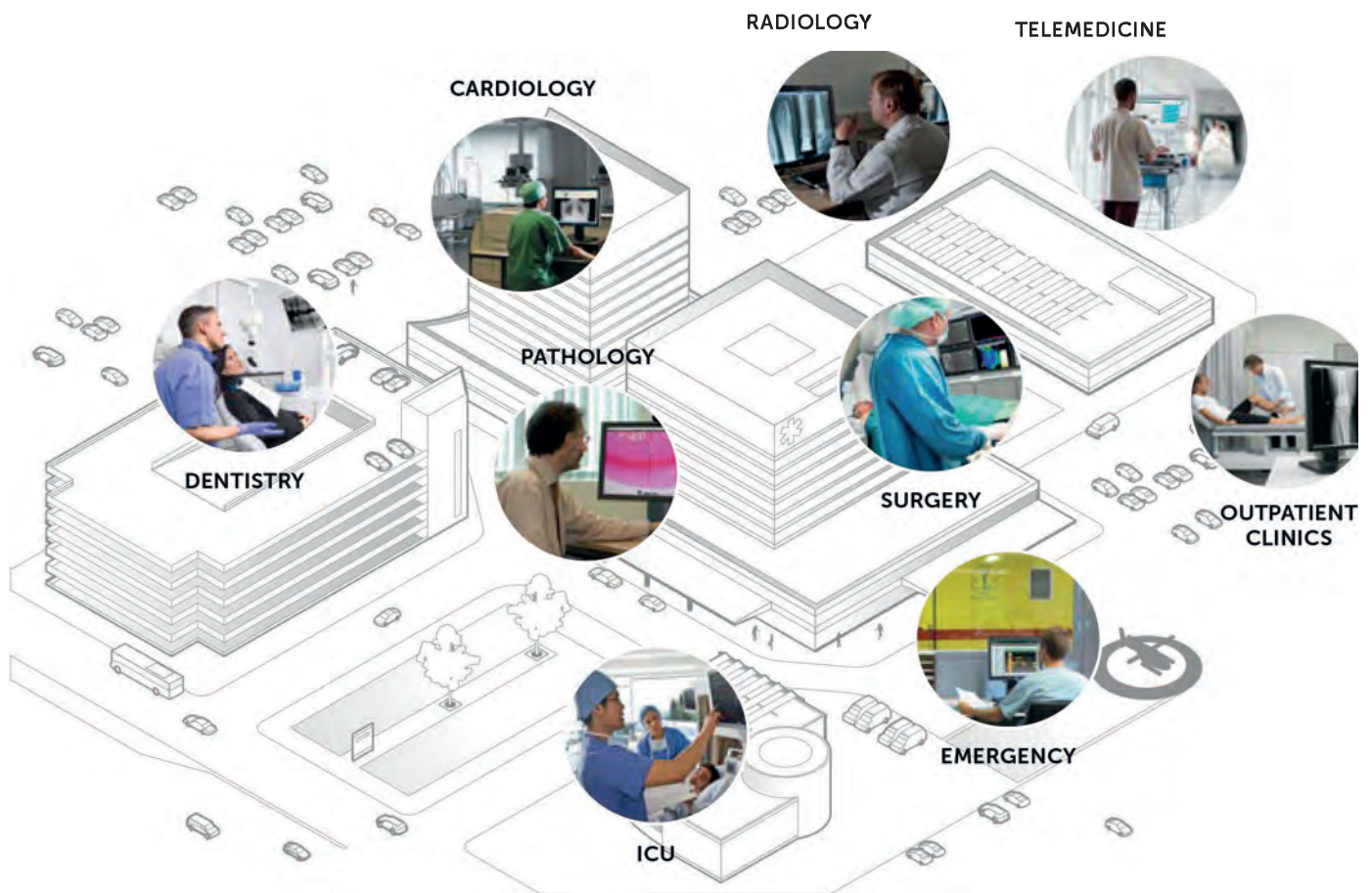

Recognized as the Visionary Innovation Leader in medical displays by Frost & Sullivan

Coronis Uniti®

mammography radiology



Coronis Fusion

radiology



Diagnostic displays

Coronis

mammography

radiology



Nio

mammography

radiology



Diagnostic displays



Clinical displays

dentistry

EMR

other



Surgical displays

surgery



Smart displays and user interfaces



KEYBOARDS
AND MICE FOR
HYGIENE-SENSITIVE
AREAS

washable-keyboards.com





Millions of germs that can cause sicknesses are on the move directly under your fingers. As a result, your keyboard can become a real problem area!

Keyboards and mice are an ideal environment for germs and bacteria. Dirt collects at the most inaccessible points and that makes them difficult to clean. This gives rise to potential hazardous situations for hygiene-sensitive areas like food production or the health sector. But it also affects traditional PC workstations in offices. We therefore recommend that you use specially developed keyboards and mice. We can supply you with an extensive range of washable keyboards and mice to meet any requirements.

The choice ranges from a washable office keyboard to a waterproof professional keyboard for use in critical hygiene areas. In addition to the standard products that are available, we can handle your individual special wishes like printed logos or special keyboard layouts. We also develop and produce completely new data input components and devices for medical engineering applications.

WHY WASHABLE KEYBOARDS?

- To protect patients, personnel and employees from pathogens
- To improve the overall hygiene situation
- To prevent any nosocomial infections
- To guarantee that infections are kept in check in the health sector and the food processing business
- To provide cleanliness and hygiene at traditional PC workstations too
- To reduce patient treatment times and downtimes

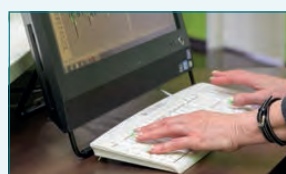

Digta▶▶

SIMPLY PROFESSIONAL DICTATION

Digta SonicMic 3

*The advantages are right there
in your hand.*



turn voice into  action

GRUNDIG
Business Systems

Digta SonicMic 3

For professional dictation and speech recognition

Pushbutton controls

The Digta SonicMic 3 allows you to control recording with minimal movement of your thumb, allowing your concentration to remain fully on the text.

Mouse controls

The optical trackpad allows unerring navigation on the screen. If desired, the mouse can be controlled with the trigger button on the back side of the microphone or with the left and right mouse buttons next to the trackpad.

Customizable function buttons

All function buttons can be freely configured for your personal workflow. They can be programmed for speech recognition functions.

Ergonomics

No matter what position is most comfortable for you, the microphone lies light and easy to grasp in your hand without sticking to your skin.



Optimized for speech recognition

- New microphone technology with optimized frequency response for the highest recognition rate
- Polished button surfaces dampen noise
- Direct interface with DigtaSoft Voice and Dragon Naturally Speaking speech recognition applications
- Honoured by Nuance for best recognition precision



Digta SonicMic 3 Classic

Also available in the Digta SonicMic 3 Classic version. The low-cost alternative without trackpad mouse controls.



Pland for Healthcare

CI/SfB January 2016
| (7-) | h3 | |
Uniclass L721/L83/L852



Pland

Strength in stainless steel

Hygiene Equipment Designed For People



TR EQUIPMENT





TR EQUIPMENT

Hygiene Equipment Designed For People

The TR Equipment product range meets all your hygiene and work safety related needs working with assisted bathing, institutional bathing and assisted showering when:

Transferring -Transporting -Bathing -Showering

your residents, letting you provide excellent care and well being with greater flexibility and staff productivity. TR offers Hygiene Equipment Designed for People in three different product segments Shower, Bath and Mobile Lifts. TR also offer products to meet your rehabilitation needs.

The product range covers height adjustable bathtubs, patient lifts and the markets widest shower trolley program with several options regarding sizes and Working Load Limits (WLL), both battery and hydraulic operated. The product range for shower trolleys covers standard sizes as well as pediatric and bariatric models.

Product Overview



Showers

TR Equipment offer the markets widest shower trolley program with many different options regarding sizes and Working Load Limits (WLL), both battery and hydraulic operated.

Shower chair WLL = 200 kg / 440 lbs -Battery operated Height adjustable Forward tilt and recline

To Hydraulic or Battery operated shower trolley with capability of 450 kg/ 1000 lbs

with three different stretcher lengths 1600 mm, 1900 mm, 2100 mm



Baths

TR Equipment offer a wide range of assisted height adjustable bath products with several wellness options as Cleaning Whirlpool Auto fill with availability also with Stainless steel tub & Burn treatment



Mobile Patient Lifts

TR Equipment offer patient lift products for bathing and transport. The range includes a selection of mobile chair, stretcher and combi patient lifts. Mobile Patient Bath Lifts with battery operated height adjustment available in different models. all suitable for transfer, transport and bathing for many type of residents in many different care environments.



RADIOPRO

TECH

Radioprotection & Nuclear Medicine





Workstation

Closed configuration

Shielded isolator

Semi-open configuration

Shielded Biosafety Cabinet

Opened configuration

Integrated Workstation

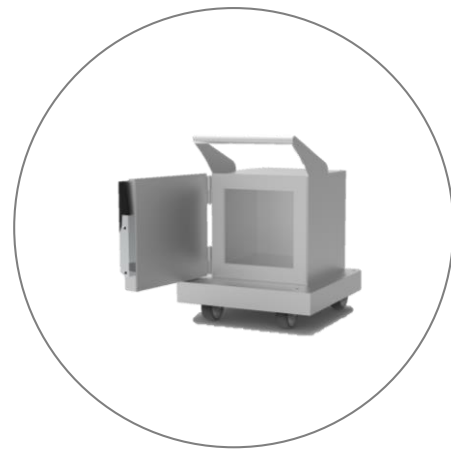

Isotopes storage

Mini storage

Under-bench storage cabinet



Sources transportation

For vials

For syringe

Syringe carrier

Wall pass-through



Waste management

Waste containers

Sharp container

Waste container trolley



L-Block and Barrier shields

Mobile shield

Injection shield

Tabletop shield



Preparation Equipment

Syringe shield and rack

Vial shield and vial tong

Dry block heater

Vortex mixer

Specific uses



MRI compatible



Synthesis modules



For betas radiation

MRI Compatible



Syringe shield non-magnetic



Injection shield non-magnetic



Syringe carrier non-magnetic



FDG syringe carrier non-magnetic



Wall pass-through



Syringe carrier



For syringe



For vials

ENTIRE HEALTHCARE/PLUMBING SOLUTIONS



Behavioral Healthcare



Acute Healthcare



Medical Office Buildings



Long Term Healthcare



Rehabilitation

United States Based Plumbing Solutions Manufacturer



Whitehall Manufacturing

Manufacturer of Healthcare and Rehabilitation Products since 1946

Whitehall Manufacturing is a North American manufacturer that serves the healthcare and rehabilitation markets. Our products are made from high-quality, durable materials that work reliably year after year.

Whitehall's products for healthcare include patient care units, scrub sinks, bariatric toilets, dialysis boxes, ligature resistant plumbing fixtures and restroom accessories. Rehabilitation products include hydrotherapy whirlpools, dry heat therapy, moist heat therapy, cold therapy, paraffin tanks and splint pans. These products help healthcare practitioners and therapists provide effective treatment to their patients.

Whitehall Manufacturing has representatives and distributors in every US state and many other countries. Our products can be found in healthcare facilities, and rehabilitation centers all over the world.



MANUFACTURING CAPABILITIES

- Fabrication
- Machining
- Assembly
- Polishing and Plating
- Pattern Shop Injection Molding
- Painting and Powder Coating
- Injection Molding

PLUMBING/CODE EXPERTS

- Design to ADA standards
- Design to bariatric requirements
- Design for behavioral healthcare
- Design to individual state requirements
- International expertise, with offices in Canada
- Mexico, the UK and Dubai
- International codes - CSA, UL, FDA approvals

SPECIALITIES

- Steel - stainless steel and galvanized
- Molding of solid surface materials including Bio Resin
- Molding of concrete/Terrazzo

Whitehall Manufacturing family of products

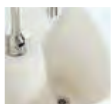

INFECTION PREVENTION SINKS



SCRUBWARE - SCRUB SINKS.



BESTCARE - BEHAVIORAL HEALTHCARE

CAREWARE - PERSONAL CARE UNITS.



BARIATRIC PRODUCTS/DIALYSIS BOXES

CUSTOM SINKS



REHABILITATION/WHIRPOOLS..



A Member of the US Green Building Institute for 15 years



References List

Some of our Highlighted Projects

Abdali Medical Centre - Clemenceau Hospital 2017-2018

King Hussein Cancer Centre inpatient tower and outpatient building 2014

King Hussein Cancer Centre inpatient tower outpatient building VIP Suite 2015

Princes Haya Hospital 2017-2018

Dr. Jamil Totanji Hospital 2017

Prince Talal Military Hospital 2017

Al Shouneh Hospital 2017

Prince Ali Military Hospital 2017

Al Karak Governmental Hospital 2017-2018

Princess Salma Hospital 2017-2018

Queen Alia Military hospital 2017-2019

Al noor sanatorium-2018

Iman Hospital– Extension / Ajloun 2015-2017

Farah Medical Campus-2018

Queen Rania Pediatric Hospital

KADDB(JLVMC)-Ambulance cars-2012-up to now

Rahma Hospital -2013

Badia'a Hospital-2013

Ibn al haitham EXT-2013

Royal Rehabilitation Centre-2014

Queen Rania Abdulla Hospital-2014

Queen Alia Heart Institute-2014

Ma'an Governmental Hospital-2014

Al-zarqaa Hospital-2014

Al-Ramtha Governmental Hospital-2014

Al-Mafraq Gynecology Hospital-2014

Queen Alia Hospital – 2016

Royal Medical Services -2016

Al Basheer Hospital -2016

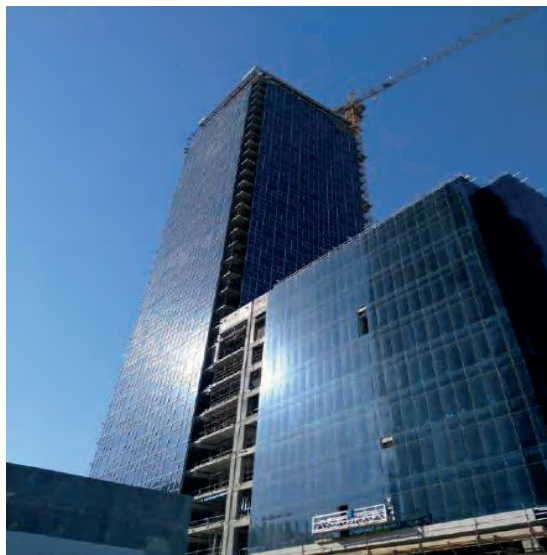

References List

Some of our Highlighted Projects

Nizar AL Naqeeb building renovation of Surgical & ICU section – KHCC- 2021

AL Bashir Hospital COVID -19 Section- MOH – 2020-2021

AL Hussein Hospital – EHS – 2020-2021

AL Rashed Hospital COVID -19 – 2020-2021

JRMS & MOH –EHS Package -2020

AL Bashir Hospital COVID -19 Section – UNOPS - 2020

Nizar AL Naqeeb building renovation of 4th floor - KHCC – 2019/2020

AL Kindi Hospital – 2019-2020

Ray One Radiology & Diagnostic Medical Center – 2020

Nizar AL Naqeeb building renovation of 5th floor Patient rooms – KHCC – 2019

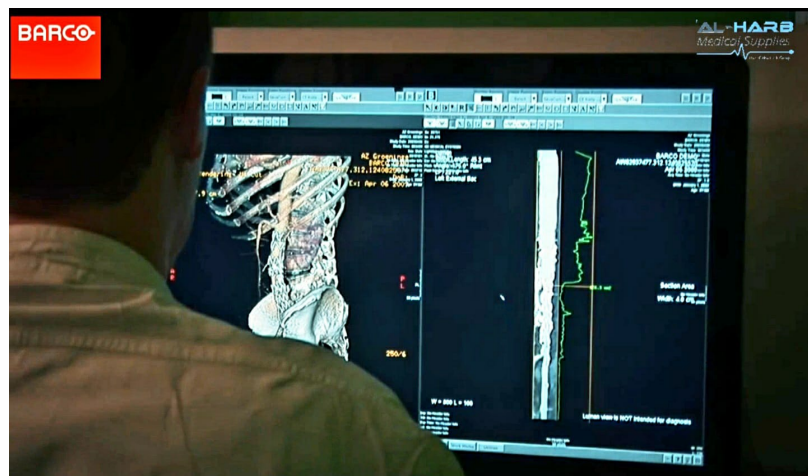



Jordan : +962 799166699



Canada &USA: +1 (647) 556-8804



info@abuharb.net



Headquarter Location
Amman , Jordan

Building Number 66 , Office Number 408 Wasfi AL Tal St

Landline: +962(6)5686067 Fax:+962(6) 5627255

WE CARE